

**Product Code:**

LFS

**Product Range:**

Lighting Trunking

**Issue Date:**

9/4/2026

**Description:**

Light Fitting Suspension

**Features:**

- Assembly designed to provide secure anchorage for lighting suspended from lighting trunking system.
- Supplied with 20mm long brass bush and lock ring.

**Technical:****Product Type** Accessories**Width** 50mm**Height** 50mm**Weight** 0.05 Kgs**Diameter** 20mm**Material** Pre-Galvanised Steel (Zinc Coated) / Brass**Colour/Finish** Self Colour**Standards** BS EN 10346:2015

The approximate weights given are for pre-galvanised finish only, in kilograms (nominal) and subject to material thickness tolerance.

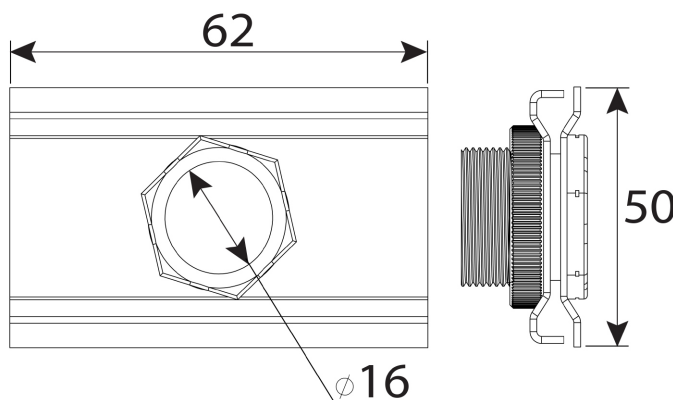
**Dimensions: (mm)****H** 50mm**W** 50mm**P1** 25mm**Important:**

To ensure optimal performance and safety, trunking must be installed so that the lid does not bear any cable weight. Incorrect installation may affect the integrity of the system and is not recommended.